

REVISION HISTORY			
REV	DESCRIPTION	DATE	REVISED BY
A	PRODUCTION RELEASE, ECO 4452	06/16/12	J.CHEN
B	REVISED PER ECO 4557	09/25/12	J.CHEN

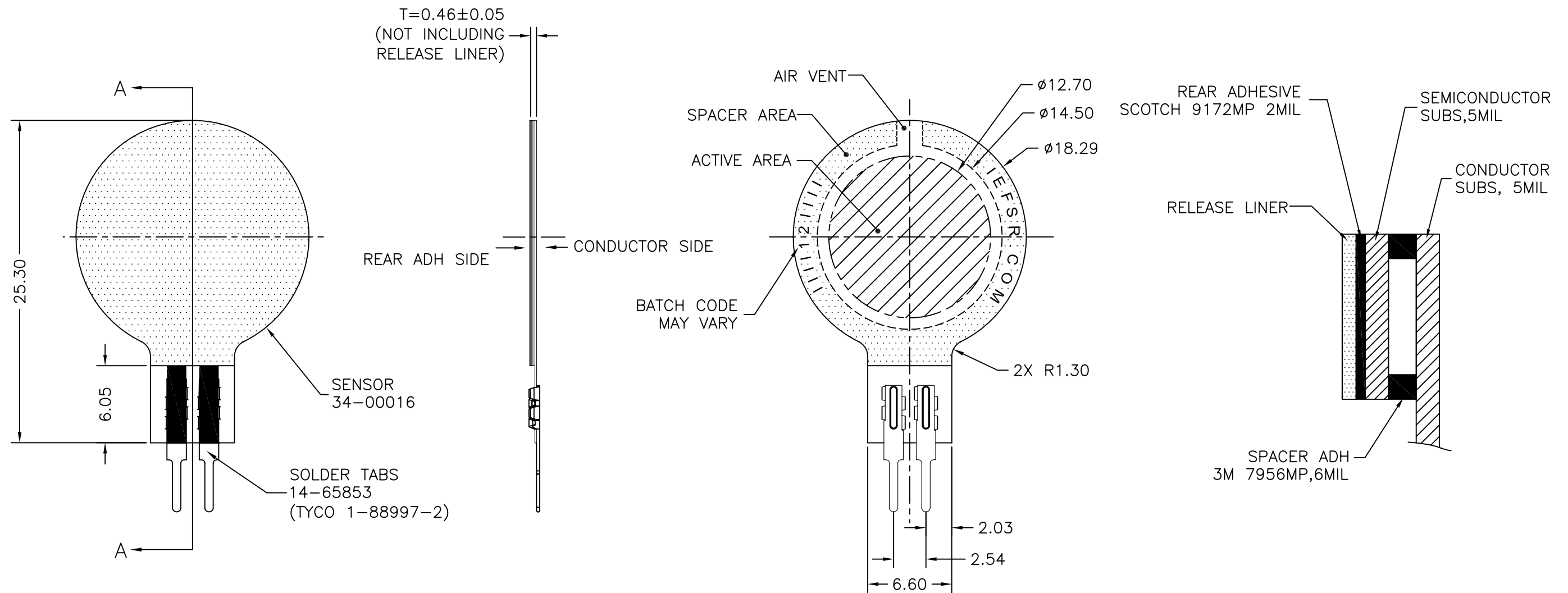

SECTION A-A  
SCALE: N/A

NOTES: UNLESS OTHERWISE SPECIFIED

- THIS ASSEMBLY TO COMPLY WITH THE LATEST REVISION OF INTERLINK ELECTRONICS SPECIFICATION 80-20016, "STANDARD FOR ENVIRONMENTAL RELATED SUBSTANCE CONTROL".
- ALL PARTS MANUFACTURED TO THIS DRAWING MUST COMPLY WITH SQS 2002 SUPPLIER QUALITY SYSTEMS REQUIREMENTS. THE LATEST VERSION CAN BE DOWNLOADED FROM OUR WEBSITE: [www.interlinkelectronics.com/supplier](http://www.interlinkelectronics.com/supplier).
- MATERIAL: SEE SEPARATE BILL OF MATERIALS.
- BUILD PARTS PER INTERLINK ELECTRONICS MANUFACTURING INSTRUCTION DOCUMENT P/N 38-00015.
- INSPECT PARTS PER INTERLINK ELECTRONICS QA INSPECTION PROCEDURES DOCUMENT P/N 39-00015.
- NO DEFECTS SUCH AS DUST, FOREIGN PARTICLES, OILS, DENTS, CREASE, BUBBLES, LOOSE FIBERS, CRACKS, NICKS, TEARS AND CONTAMINATION ARE ALLOWED.

-- TOLERANCES -- UNLESS OTHERWISE NOTED			THE MATERIAL CONTAINED IN THIS DOCUMENT IS INTERLINK ELECTRONICS PROPRIETARY INFORMATION AND MUST NOT BE COPIED OR TRANSFERRED IN WHOLE OR IN PART WITHOUT THE EXPRESSED WRITTEN PERMISSION OF INTERLINK ELECTRONICS, INC.		 <b>INTERLINK ELECTRONICS</b> Sensor Technologies		INTERLINK ELECTRONICS, USA 546 FLYNN ROAD, CAMARILLO, CA. 93012 INTERLINK ELECTRONICS, CHINA 1F, TOWER 5, LIANG TANG IND. PARK DANZHOUTOU VILLAGE, BUJI, LONG GANG REGION, SHENZHEN GUANGDONG, 518114	
DECIMAL	TOL.	ANGLES	DESIGNED	DATE	TITLE			
.XX	±.20	±0.50°	C.DENG	05/10/12	MODEL 402, 12.7MM CIRCLE, SHORT TAIL, W/SOLDER TABS			
THIRD ANGLE PROJECTION			CHECKED BY	DATE	SIZE	SCALE	DWG. NO.	REV.
			J.CHEN	05/10/12	A3	NONE	34-00015	B
MATERIAL			APPROVED	DATE	UNLESS OTHERWISE SPECIFIED, UNITS ARE IN MILLIMETERS.			
3			J.LEONARD	05/10/12	DO NOT SCALE DRAWING SHEET 1 OF 1			
SOURCE: AUTOCAD								